



ZANOTTI Spa

Via M.L. King, 30
46020 - Pegognaga (MN) - ITALY
Tel. +39 0376 5551
Fax +39 0376 536554
info@zanotti.com

a member of **DAIKIN** group

Datenblatt

Ausführung 2.2

Modell:

BGM320DB11XA

Kategorie:

GM

Technische Daten

Eigenschaften	M.U.	Wert
Betriebstemperatur	°C	-15 ÷ -25
Art des Antriebs		Direkt
Spannung	Volt-Ph-Hz	380-400/3N~/50
Nennaufnahme	kW*	2,10
Nennaufnahme	Amp*	4,70
Anlaufstrom	Amp	28,0
Strom max.	Amp	9,5
Kühlmittel		R452A
	GWP	2140
Abtauzyklus		Heißes Gas
Gewicht	Kg	105

Kompressor

Typ		Hermetisch
Nennleistung	kW	1,5

Kondensator

Luftmenge	m³/h	1500
-----------	------	------

Verdampfer

Luftmenge	m³/h	1800
Wurfweite	m**	10

Kategorie PED		0
---------------	--	---



Leistungsdaten

Tc °C	Ta °C	P watt	P Kcal/h	V120 m³	V100 m³	V80 m³
	20	3323	2858	45	40	35
	25	3139	2700	41	36	32
-15	30	2918	2509	36	32	28
	35	2672	2298	31	28	24
	40	2416	2078	27	24	21
	45	2162	1859	22	20	17
	20	2849	2450	35	31	27
	25	2684	2308	32	28	25
-20	30	2491	2142	28	25	22
	35	2276	1957	24	21	19
	40	2045	1759	20	18	16
	45	1802	1550	17	15	13
	20	2377	2044	26	23	20
	25	2212	1902	23	20	18
-25	30	2035	1750	19	17	15
	35	1848	1589	17	15	13
	40	1655	1423	15	13	12
	45	1459	1255	12	11	9,4

* Bei Betrieb: -20 ÷ +30°C

** Standartwert, der Luftwurf ist von zahlreichen Faktoren abhängig: Kühlzellenhöhe, Lagerart, Verdampfer Montageort, usw.

Tc: Raumtemperatur. - Ta: Aeussere Temperatur.

P: Abkühlende Kapazität - V: vorgeschlagen Kühlraum Volumen

L'immagine è datata e potrebbe presentare alcune differenze rispetto all'unità attuale. La aggiorneremo il prima possibile.
 The picture is old and it could have some differences from the current unit. We will update it as soon as possible.

Dimensioni - Dimensions - Dimensions
 Abmessungen - Dimensiones

GM3

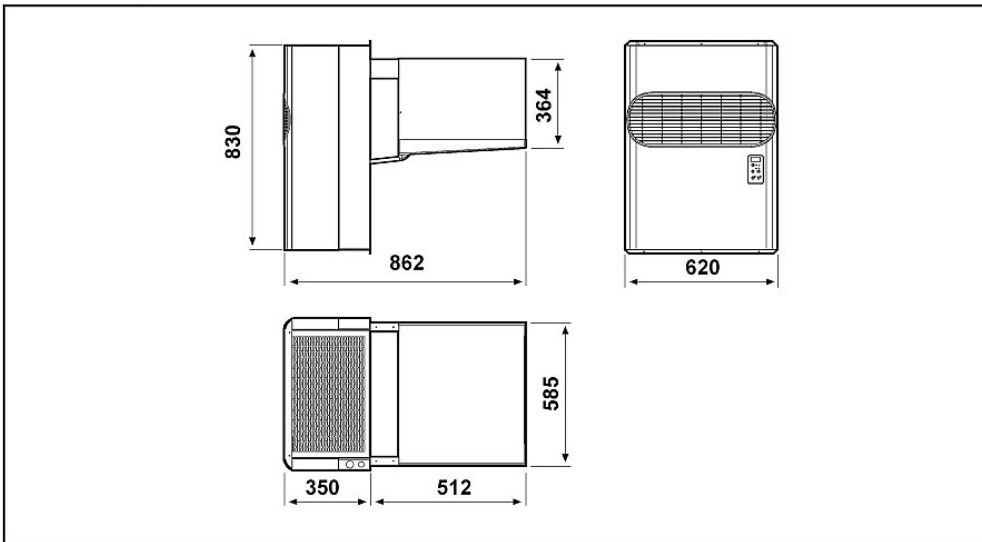

Schema di montaggio - Mounting scheme - Schema de montage
 Montageschema - Esquema de montaje

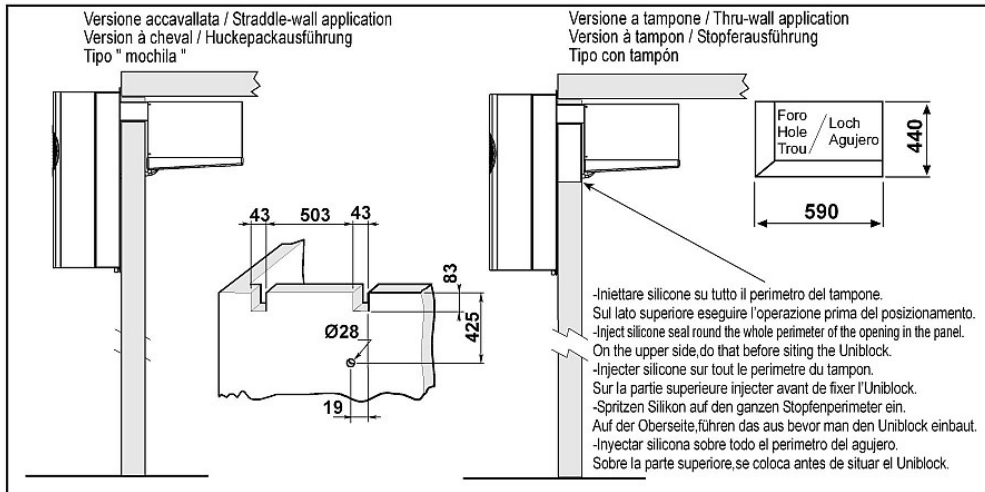

- * Raccomandazioni in sede di installazione e per il controllo fornite sul manuale di installazione
- * To be advised at time of order for factory installation and operating instructions
- * Recommendations au moments d'installations et pour le contrôle fournis sur le manuel d'installation
- * Empfehlungen für die Installationsphase und zur Kontrolle, die im Handbuch zur Installation enthalten sind
- * Por cuanto respecta a recomendaciones de instalaciòn y control ver manual de instalaciòn

Massa e misure imballi - Packing mass and dimensions - Masse et dimensions emballages
 Verpackungsmasse und-abmessungen - Masa y medidas del embalaje

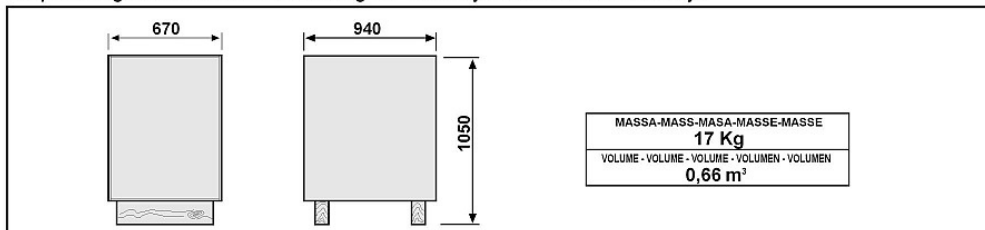

ZANOTTI S.p.A.